

SUBJECT: PART NUMBER INFO: EXTENSION CABLE

DATE: APRIL 1997

MODEL (S): MDS-JE500

MDM-3A

FOR INTERNAL USE ONLY

The following Extension Cable is now available:

Part Number	No. of Terminals (1mm pitch)	Usage
J-2501-124-A	5P 1MM	CHECKING RF WAVEFORM

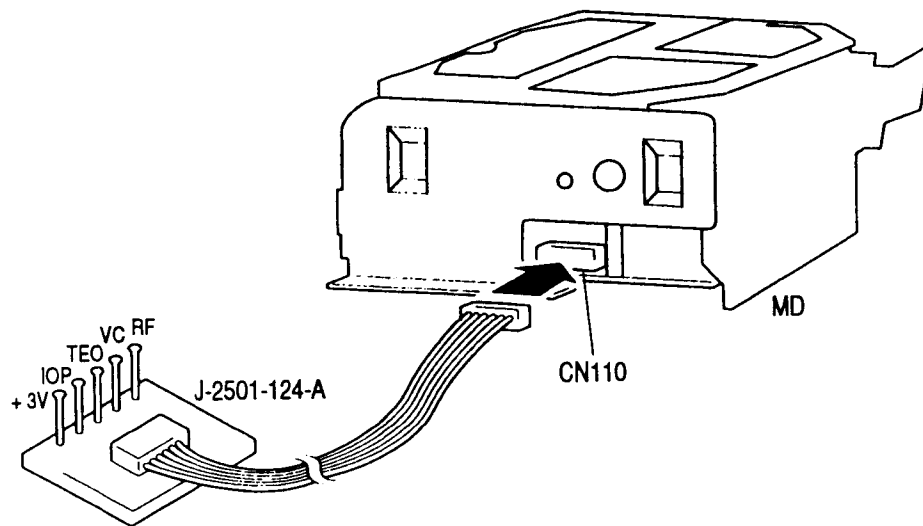
AU01197
AU97007